

LiFePO₄ battery pack

User Manual

(Elephant-48628)



1 Summary

The Cart-48800 is a low-voltage, high-capacity lithium iron phosphate battery pack designed for backup power in households, communication devices, and outdoor performances.

1. Product Features

*The positive electrode of the cell is made of lithium iron phosphate material, safe and reliable;

*The battery management system (BMS) features intelligent protection against overcharging, over-discharging, overcurrent, short circuits, and extreme temperatures.

*Flexible configuration and large capacity allow multiple modules to be used in parallel to increase service time and power.

*Built-in mainstream inverter communication protocols (e.g., Panneng, Gurewatt, Deye) enable effortless smart management.

* Passive heat dissipation mode, no noise.

1.2 Service environment

Environmental requirements

The battery pack should be operated in an environment without corrosive, flammable and explosive gases or objects, and should be far away from conductive dust and heat sources.

Environmental temperature, humidity, and pressure range

Discharge ambient temperature: $-15^{\circ}\text{C}\sim 60^{\circ}\text{C}$;

Storage temperature: $10^{\circ}\text{C}\sim 35^{\circ}\text{C}$;

Relative humidity range: $\leq 95\%$ ($45^{\circ}\text{C}\pm 2^{\circ}\text{C}$);

Relative humidity range for storage and transportation: $\leq 95\%$ ($45^{\circ}\text{C}\pm 2^{\circ}\text{C}$);

Atmospheric pressure range: $70\sim 106\text{k Pa}$.

2 Product description

1. Key technical specifications

Specification Name	Elephant-48628
Battery type	LiFePO4(LFP)
Rated voltage	51.2V
Rated capacity	628Ah
Rated energy	32.15kWh
Charge termination voltage	58.4V
Discharge cutoff voltage	44.8V
Recommended charging current (Per Port)	150Ah*2
Maximum continuous charging current (Per Port)	150A*2
Maximum continuous discharge current (Per Port)	150A*2
Cycle life	6000
Contact method	CAN\RS485
Size	1000*340*900mm
Weight	Approximately 242kg

2.2 Panel interface diagram and description

175A Anderson *2
(Battery charging and
discharging interface.)

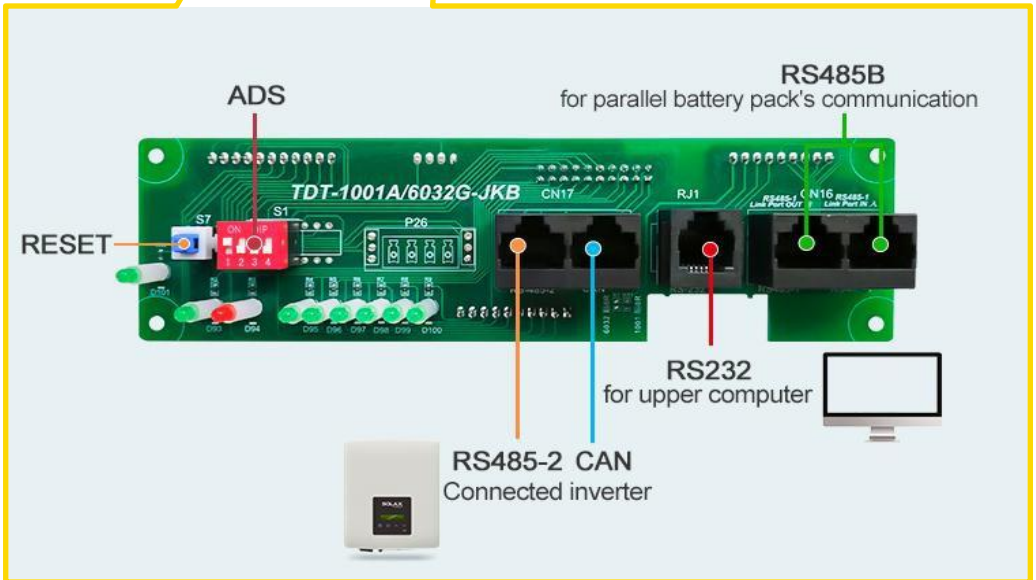
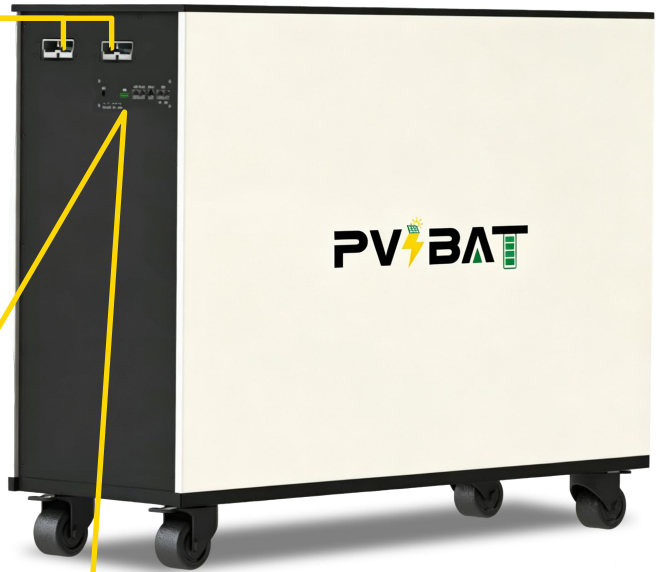

2.3 LED instructions

状态 (State)	正常/告警/保护 (Normal/alarm/ protection)	POWER	RUN	ALM	SOC(电量指示 power indicator LED)						说明(Instruction)	
												
关机 (Shut down)	休眠(Sleep)	灭 off	灭 off	灭 off	灭 off	灭 off	灭 off	灭 off	灭 off	灭 off	灭 off	全灭 All off
待机 (Standby)	正常(Normal)	常亮 on normally	闪 1 Flash1	灭 off	依据电量指示 According to battery indicator						待机状态 Standby state	
	告警(Alarm)	常亮 on normally	闪 1 Flash1	闪 3 flash3							模块低压 Module of low voltage	
充电 (Charging)	正常(Normal)	常亮 on normally	常亮 on normally	灭 off	依据电量指示(电量指示最高 LED 闪 2) According to battery indicator(Battery indicator maximum LED flash 2)						最高电量 LED 闪动(2) , 过充告警时 ALM 不闪烁 Maximum power LED flash (2), ALM does not flash when the overcharge alarm is generated	
	告警(Alarm)	常亮 on normally	常亮 on normally	闪 3 flash3								
	过充保护 (Overcharge protection)	常亮 on normally	常亮 on normally	灭 off	常亮 on normally	常亮 on normally	常亮 on normally	常亮 on normally	常亮 on normally	常亮 on normally	若 无 市 电 ， 指 示 灯 转 为 待 机 状 态 If there is no mains supply, the indicator is in standby state	
	温度、过流、失效 保护 (Temperature, over current, fail-safe protection)	常亮 on normally	灭 off	常亮 on normally	灭 off	灭 off	灭 off	灭 off	灭 off	灭 off	灭 off	停止充电 Stop charging

2.3 LED instructions

放电 (Discharging)	正常(Normal)	常亮 on normally	闪3 flash3	灭 off	依据电量指示 According to battery indicator							
	告警(Alarm)	常亮 on normally	闪3 flash3	闪3 flash3	According to battery indicator							
	欠压保护 (Under-voltage protection)	常亮 on normally	灭 off	灭 off	灭 off	灭 off	灭 off	灭 off	灭 off	灭 off	灭 off	停止放电 Stop discharging
	温度、过流、短路、反接、失效保护 (Temperature, over current, short-circuit, reverse connection, fail-safe protection)	常亮 on normally	灭 off	常亮 on normally	灭 off	灭 off	灭 off	灭 off	灭 off	灭 off	灭 off	停止放电 Stop discharging
失效 (Failure)		灭 off	灭 off	常亮 on normally	灭 off	灭 off	灭 off	灭 off	灭 off	灭 off	灭 off	停止充、放电 Stop charging and discharging

容量指示说明(Capacity indications)

状态State		充电Charge 6个LED						放电Discharge 6个LED					
容量指示灯Capacity indicator		L1	L2	L3	L4	L5	L6	L1	L2	L3	L4	L5	L6
电量 (%) Power	0~17%	闪flash	灭off	灭off	灭off	灭off	灭off	亮on	灭off	灭off	灭off	灭off	灭off
	18~33%	亮on	闪flash	灭off	灭off	灭off	灭off	亮on	亮on	灭off	灭off	灭off	灭off
	34~50%	亮on	亮on	闪flash	灭off	灭off	灭off	亮on	亮on	亮on	灭off	灭off	灭off
	51~66%	亮on	亮on	亮on	闪flash	灭off	灭off	亮on	亮on	亮on	亮on	灭off	灭off
	67~83.0%	亮on	亮on	亮on	亮on	闪flash	灭off	亮on	亮on	亮on	亮on	亮on	灭off
	84.0~100%	亮on	亮on	亮on	亮on	亮on	闪flash	亮on	亮on	亮on	亮on	亮on	亮on

LED 闪动说明 (Flashing instructions)

闪动方式(Flash mode)	亮(On)	灭(Off)
闪1 Flash1	0.25S	2.75S
闪2 Flash2	0.25S	0.75S
闪3 Flash3	0.25S	1.75S

2.4 拨码开关设置(Dial switch)

当 PACK 作并联使用时, 可通过 BMS 上的拨码开关设置地址区分不同的 PACK, 需避免地址设为相同, BMS 拨码开关的定义参照下表。When connect several battery PACKs in parallel, you can distinguish different PACKs by setting the address through the Dial switch on the BMS. It is necessary to avoid setting the same Address. Following is the Dial switch definition.

地址 序号	拨码 图示	拨码开关位置			
		#1	#2	#3	#4
1		ON	OFF	OFF	OFF
2		OFF	ON	OFF	OFF
3		ON	ON	OFF	OFF
4		OFF	OFF	ON	OFF
5		ON	OFF	ON	OFF
6		OFF	ON	ON	OFF
7		ON	ON	ON	OFF
8		OFF	OFF	OFF	ON

地址 序号	拨码 图示	拨码开关位置			
		#1	#2	#3	#4
9		ON	OFF	OFF	ON
10		OFF	ON	OFF	ON
11		ON	ON	OFF	ON
12		OFF	OFF	ON	ON
13		ON	OFF	ON	ON
14		OFF	ON	ON	ON
15		ON	ON	ON	ON

2.5 复位开关说明(The instruction of dry contact and reset switch)



复位开关:
Reset switch

BMS 处于激活状态时, 按下按键 (3~6S) 后松开, 保护板被休眠(无充电), LED 指示灯从最低电量灯开始依次点亮 0.5 秒。When the BMS is in the active state, press the button (3~6S) and release it, the BMS is hibernated (no charge), and the LED indicator lights are on successively for 0.5 seconds from the lowest power indicator.

BMS 处于激活状态时, 按下按键 (6~10S) 后松开, 保护板被复位, LED 灯全部同时点亮直到复位结束。When the BMS is in the activated state, press the button (6-10s) and release it, the BMS is reset, and all LED lights are on at the same time until the reset is complete.

BMS 被复位后仍保留通过上位机设置的参数和功能, 如果需要恢复到初始参数可以通过上位机的“恢复默认值”来实现, 但相关运行记录和存储数据保持不变 (如电量、循环次数、保护记录等)

After the BMS is reset, the parameters and functions set by the upper computer are still retained. If the initial parameters need to be restored, it can be achieved by "restoring default values" of the upper computer, but the relevant running records and stored data remain unchanged (such as power, cycle times, protection records, etc.).

2.6 自动拨码(Automatic dial)

	自动拨码开关: Automatic dial switch	所有并机BMS拨码开关需在“OFF”状态, 如图所示 All parallel BMS dip switches should be in the "OFF" state, as shown in the figure
--	----------------------------------	--

- 11.5.1. 将 RS485 并机按照正确的方式连接, 主机 BMS 网线一端插在 Link Port OUT 网口, 另一端插在第二台并机 Link Port IN 网口, 第二台并机网线一端插在 Link Port OUT 网口, 另一端插在第三台并机 Link Port IN 网口, 依次接入并机通讯线, 位置不得接错, 不然会导致地址分配不成功。
Connect correctly the RS485 in parallel. Connect one end of the main BMS network cable to the Link Port OUT network Port and the other end to the Link Port IN to the second parallel network port. Connect one end of the second parallel network cable to the Link Port OUT network port and the other end to the Link Port IN to third parallel network port. And connect parallel communication cables one by one. Please do not connect the cable to the wrong position; Otherwise, the address assignment fails
- 11.5.2. 将所有机器连接好后开机, 关闭主机弱电开关, 若并机线连接正常, 则所有的机器都会关机。打开主机弱电开关, 这时所有从机一起开机, 所有机器灯板上所有的灯开始闪烁, 等待约 20 秒, 主机显示所有机器的平均 soc, 从机只有运行灯闪烁。如果有发现有闪灯不正常的, 检查并机通讯线是否 OK, 再按照以上步骤操作。
After connecting all BMS, turn all BMS on. Then turn off the on/off switch of the main BMS. If the parallel line is connected normally, all the BMS will be turned off. Turn on the on/off switch of the main BMS, and then all other BMS will turn on together. All the lights on the LED boards of all the BMS will start flashing. Wait for about 20 seconds, the main BMS will display the average soc of all battery packs, and only the running lights of the slave BMS will flash. If you find that there are abnormal flashing lights, please check whether the parallel communication line is OK or not. Then follow the above steps.
- 11.5.3. 自动拨码后, 当主机使用手动拨码开关, 其他从机可正常使用手动拨码功能, 当主机和从机拨码开关均为 OFF 状态时, BMS 地址会回归到自动拨码成功的地址。
After using the automatic DIP switch, if the manual DIP switch is used on the master BMS, the manual DIP switch can be used on other slaves. When the DIP switches of both the master BMS and slaves are OFF, the BMS address returns to the address where the automatic DIP switch is successful.
- 11.5.4. 可以通过冗余监控并机数量与实际数量是否相符。
Redundancy can be used to monitor whether the number of parallel battery packs matches the actual number.

3. RS485、CAN、RS232 接口图示和电气接口定义：

The diagram of RS485, CAN, RS232 and its definition description

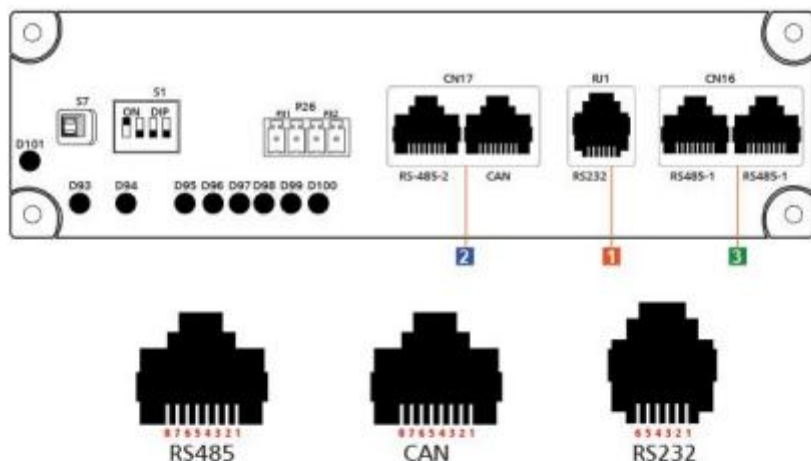

1	
RS232 -- RS232--采用 6P6C 立式 RJ11 插座 RS232 -- using 6P6C vertical RJ11 sockets	
RJ11 pin	定义说明 Definition Description
2	NC
3	TX单板 (veneer)
4	RX单板 (veneer)
5	GND

2		CAN--采用 8P8C 立式 RJ45 插座 CAN -- using 8P8C vertical RJ45 sockets	
RJ45 pin	定义说明 Definition Description	RJ45 pin	定义说明 Definition Description
1, 8	RS485-B1	1, 2, 3, 6, 8	NC
2, 7	RS485-A1	4	CANH
3, 6	GND	5	CANL
4, 5	NC	7	GND

3		RS485--采用 8P8C 立式 RJ45 插座 RS485 -- using 8P8C vertical RJ45 sockets	
RJ45 pin	定义说明 Definition Description	RJ45 pin	定义说明 Definition Description
1, 8	RS485-B	1, 8	RS485-B
2, 7	RS485-A	2, 7	RS485-A
3, 6	GND	3, 6	GND
4, 5	NC	4, 5	NC

4 System Architecture

The system operates as shown in the diagram, consisting of four main components: solar panels, an inverter, a battery pack, and the power grid. Solar or generated electricity is first converted into battery charge through MPPT (Maximum Power Point Tracking) or the inverter. During nighttime, power outages, or high electricity prices, the stored energy from the battery powers electrical devices, achieving uninterrupted operation and load balancing.

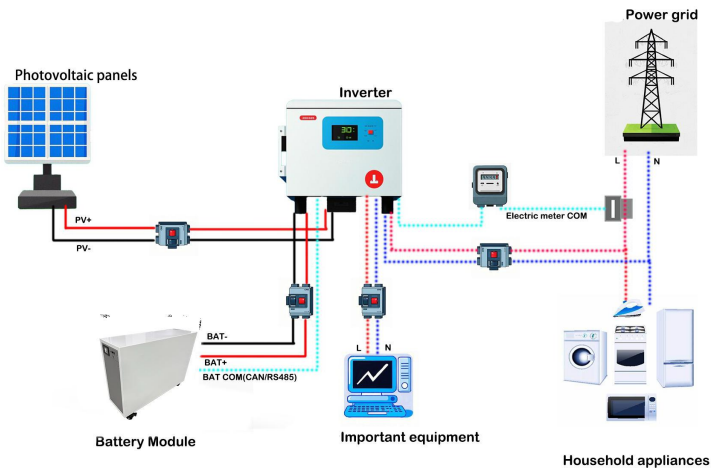

5 Installation Guide

1. Installation Notes

- (1)The product shall be installed in accordance with local laws and regulations;
- (2)The personnel responsible for installation and maintenance must first undergo strict training, master the correct operation methods and safety precautions, and then can work on installation, operation or maintenance;
- (3)During the installation process, insulation protection should be done, and it is strictly prohibited to operate with power;
- (4) Avoid battery impact and fall during installation;
- (5)Do not disassemble battery components without authorization. Battery maintenance must be performed by professional maintenance engineers.
- (6)Keep the installation environment clean, without debris or inflammable items stacked;
- (7)The installation environment shall be equipped with corresponding fire fighting equipment;
- (8) Ensure that the installation ground is flat and firm;
- (9) Avoid rain or direct sunlight.

5.2 Installation Setup

Check the outer box for damage. After opening the box, inspect the battery pack for water ingress, deformation, rust, or other abnormalities, and verify if any parts are missing. If any issues are found, contact the sales representative immediately and document them with photos or videos. If no abnormalities are detected, sign for the package as usual.

tool

NO.	name	specifications	remarks
1	electric screwdriver	/	Equipped with M4-M8 sleeves
2	spanner	M8	screwed connection
3	bolt driver	Phillips screwdriver	/

4	art knife	/	/
5	sleeve	M8	Positive and negative terminal cables
6	multimeter	/	measure
7	wire stripping pliers	/	Wiring Harness Connections
8	diagonal pliers	/	/
9	USB-RS485 communication cable	/	Battery Monitoring
10	notebook PC	/	Battery Monitoring
11	insulating gloves	/	safety protection
12	Insulated safety shoes	/	safety protection

5.3 Installation

Step 1: Move the battery pack to the required installation position. Use appropriate tools such as forklifts during the process. When pushing manually, apply force from the narrow side to avoid tipping risks caused by wide-side pressure. After securing the battery, press the wheel brake.

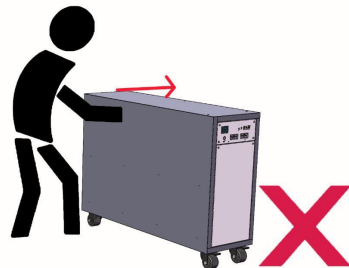
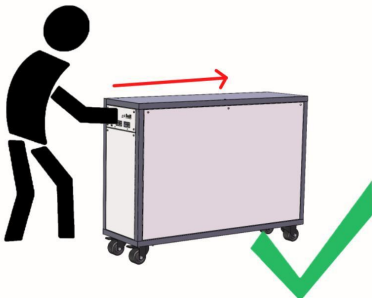

Step 2: Connect the wiring to the inverter battery input port first, then plug the wiring plug into the battery pack plug, and connect the communication line. Ensure that the other components are connected and then start the machine for verification.

Parallel Usage Instructions

When using multiple battery packs in parallel, prepare a junction box with a circuit breaker to connect them in parallel before connecting to the inverter.

6 Maintenance and disposal

1. Maintenance instructions

1. Please store the battery in a dry and well-ventilated environment. Storage temperatures that are too high or too low will affect the battery's self-discharge rate and accelerate its natural aging. The recommended storage temperature range is 20~45°C, and keep it away from water sources, heat sources, as well as other metal objects.
2. If the battery is not used for a long time, it is recommended to store it properly with the battery in a semi-charged state (60% SOC). It is advisable to discharge the battery to 30% every three months and then recharge it to 60%.
3. For safety reasons, do not store this battery in environments above 45°C or below 20°C for extended periods; to prolong battery lifespan, it is recommended to use this battery within an ambient temperature range of 20°C to 45°C.
4. If the battery level is below 1% after use, please charge it to 60% before storage. If left unused for an extended period with critically low power, irreversible damage to the battery cell may occur, shortening the overall lifespan of this battery;
5. If the battery power is critically low and left idle for an extended period, the battery will enter deep sleep mode. It must be recharged before reuse to restore functionality.

6.2 Abandonment

- 1.If conditions permit, please ensure to completely discharge this battery before placing it in the designated battery recycling bin. This battery contains hazardous chemicals and is strictly prohibited from being discarded in regular trash bins. For relevant details, please comply with local laws and regulations regarding battery recycling and disposal.
- 2.If the battery fails to complete a full discharge due to its own malfunction, do not discard it directly into the battery recycling bin. Instead, contact a professional battery recycling company for further handling.
- 3.Over-discharged batteries will fail to activate. Please dispose of them in accordance with local laws and regulations on battery recycling and disposal.

7 Frequently Asked Questions

1.After connecting the battery pack to the inverter, the inverter fails to power on. What could be the reason?

Answer: The inverter has a relatively large capacitive load. The battery pack switch should be turned on first, followed by the inverter switch, to allow the BMS pre-charging function to operate.

2. Does the battery pack experience SOC jumps after usage?

Answer: The battery pack SOC requires calibration. After disconnecting communication, follow the parameter table to complete the charge-discharge process for calibration.

3.When battery packs are connected in parallel, is there inconsistency in power and SOC between the battery packs?

Answer: Due to the resistance differences between individual battery harnesses and battery packs, those with lower resistance will be prioritized for charging or discharging, which is a normal phenomenon and does not affect actual usage.

4. Frequent power outages in the battery pack?

Answer: Check whether the load power is too high, whether the wiring harness connection is secure, and whether environmental conditions such as temperature meet the battery pack parameters.

Thank you for observing this user manual. If you have any doubts, please contact the after-sales technicians. Thank you!